



Lock System

Position locked when the valve is open or closed

SMART Vacuum Gate Valves

•Email: info@kinglai.com.tw

•Website: www.advantorr.com



Product Introduction

Vacuum gate valves are used primarily for the protection of high vacuum pumps but can also be used to 'valve-off' two connecting chambers.

The next generation of gate valves using the latest **S.M.A.R.T. technology sealing mechanism**, is designed for both superior performance and smooth, vibration free operation.

S.M.A.R.T.

Soft-shut **Mechanism with Auto-Rail Transportation Technology.**

Vacuum
Valves

SMART Gate Valves are designed to significantly reduce any vibration during operation, hence minimising particle generation and are therefore ideal for vacuum systems that require a clean environment.

SMART Gate Valves are available in two actuator orientation options; a side-mounted manual or pneumatic actuator (SGV part codes), or the **In-Axis option (AGP part codes) which has a vertically mounted pneumatic only actuator and is ideal for applications** where a small footprint is necessary. Both actuator orientations are available with the **SMART lock system** as standard.

Product Features

- No springs!

Less wear and strain means longer life

- Shock free 'soft shut' SMART technology. ■ S.M.A.R.T

The lowest vibration of any gate valve on the market

- Vulcanized seal for repeatable, maintenance free operation

- Optional welded bellows feedthrough for cleanliness and improved service life

- Fail safe locking mechanism.

Locks in both the open and closed positions

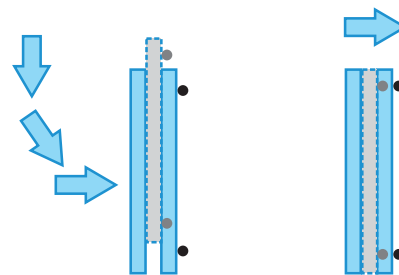

SMART mechanism seal plate operates with no vibration, ensuring particle free operation.

Conventional seal plate designs that use a spring mechanism can be susceptible to vibration during operation.

■ SMART lock system

Position locked when the valve is open or closed.

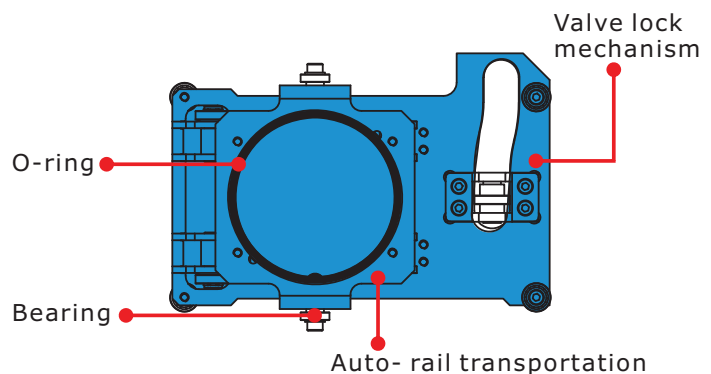

Product's Application

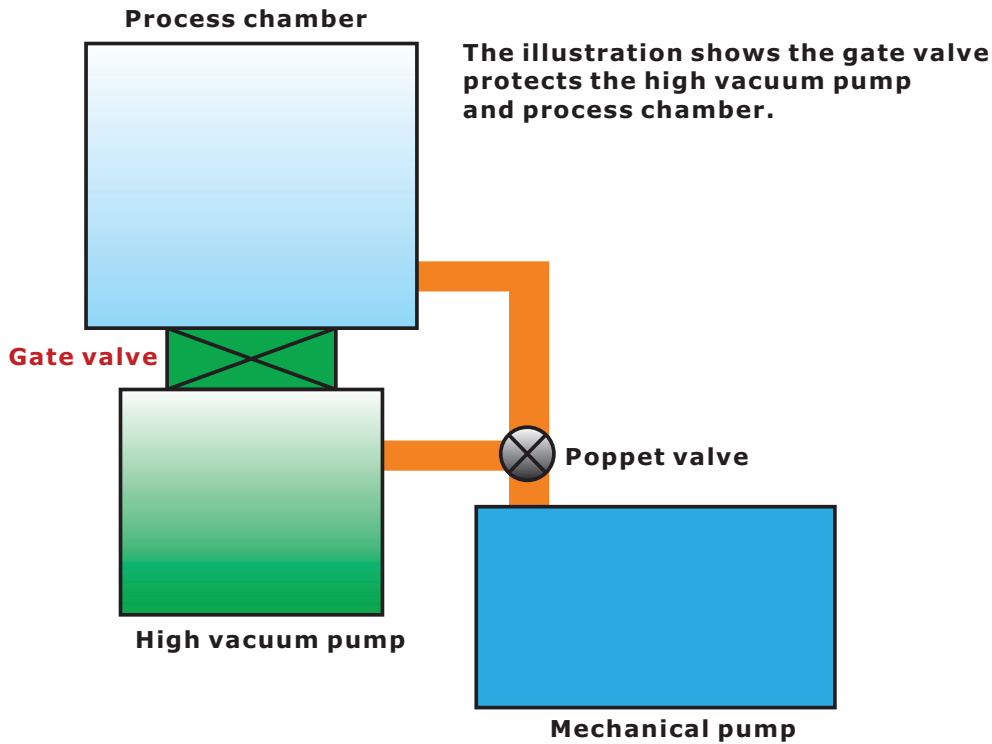

Vacuum Valves

Schematic illustrating the gate valve in position between the two tubular chambers.

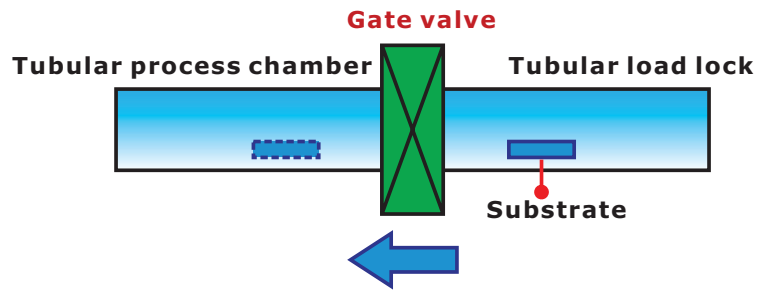

Substrate transfer from tubular load lock to tubular process chamber.

Valve's operation concept

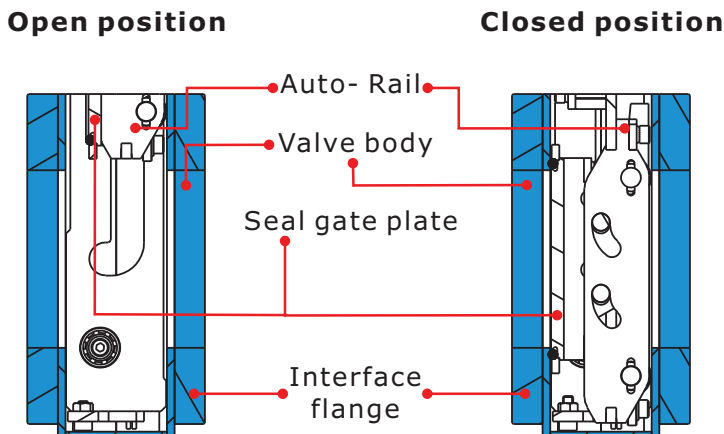

Key Valve Parts

Vacuum Valves

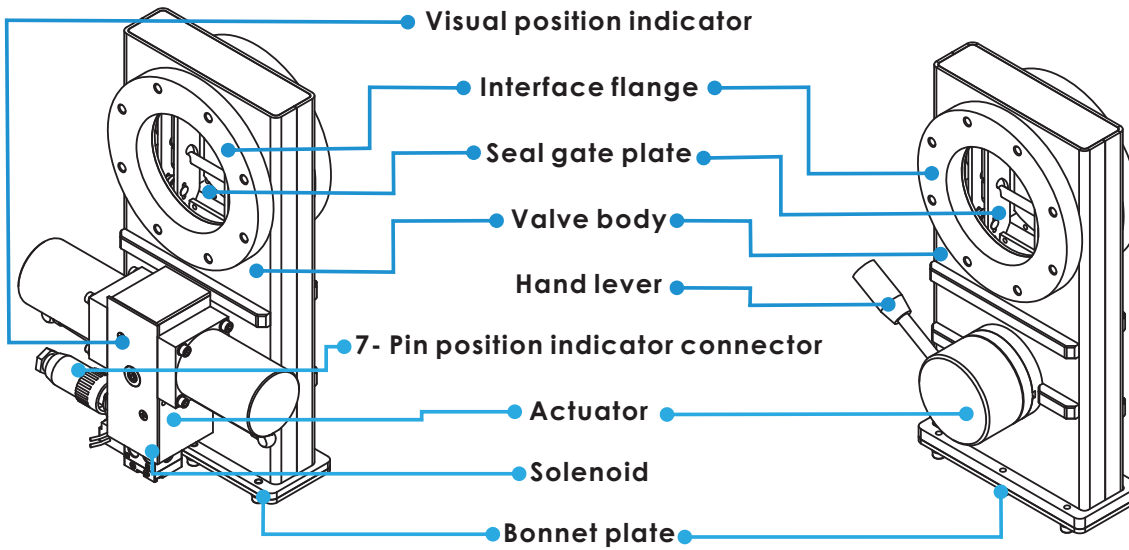

Technical Data for SMART Gate Valve

	High Vacuum
Feedthrough	Rotary type feedthrough
Gate seal	FKM o-ring (Optional for FFKM)
Bonnet seal	FKM O-ring
Operate pressure range	760 Torr ~ 1×10^{-8} Torr 1,000 mbar ~ 1.33×10^{-8} mbar 100 kPa ~ 1.13×10^{-9} kPa
Leak rate	1×10^{-9} Torr l/s, He 1.33×10^{-9} mbar l/s, He 1.13×10^{-10} kPa l/s, He
Cycle life	>200,000 Cycles
Temperature for valve body	250°C (482°F) Open, 200°C (392°F) Closed
Temperature for actuator	200°C
Temperature for solenoid / position indicator	80°C 176°F
Bake temperature	100°C (212°F) for FKM gate seal
Valve body material	SS304L (Optional for SS316L)
Mechanism material	SS304L
Actuator material	SS304L, Aluminum
Mounting position	Any

Valve's operation data

Manual lever	180 degree angle
Pneumatic operating pressure	4 bar ~ 8 bar
Position indicator (included as standard)	Visual indicator and micro switch with 7-pin connector
Solenoid (included as standard)	24V DC, standard option for 12V DC, 110V AC and 220V AC
Failure protection (included as standard)	SMART lock system (valve position remains and locked)

Valve's performance data

	CF6"/ISO-F100	CF8"/ISO-F160	CF10"/ISO-F200	CF12"/ISO-F250
Maximum differential pressure against gate	< 1,500 Torr < 2,100 mbar < 200kpa			
Maximum differential pressure at opening	<22.5 Torr <30 mbar <3 kpa	<18.7 Torr <25 mbar <2.5 kpa	<15 Torr <20 mbar <2 kpa	<11.2 Torr <15 mbar <1.5 kpa
Pneumatic valve open / close time	1.5(s)	2(s)	2.5(s)	3(s)
Valve's conductance (Molecular flow)	1,700(l/s)	5,100(l/s)	12,000(l/s)	22,000(l/s)

Product Order Information

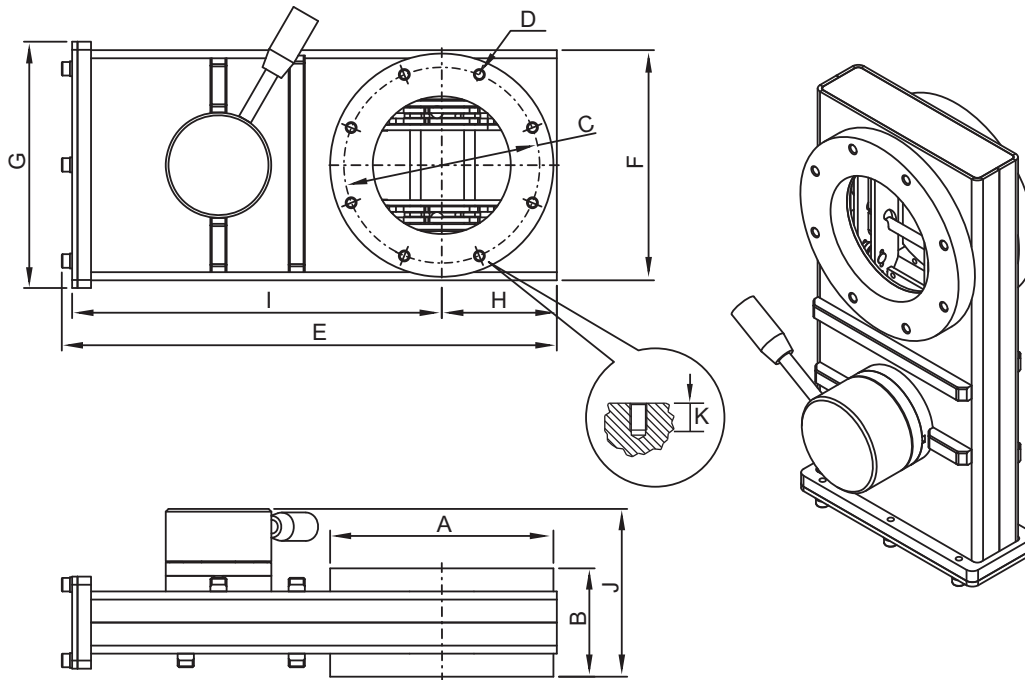

Vacuum
Valves

♦ Manual Lever SMART Gate Valves, HV, CF Flange

Dimension in mm

Nominal I.D.	Part Number - Inch	Thread D	Part Number - Metric	Thread D	A	B	C	E	F	G	H	I	J	K
DN 63 (2.5")	SGVM-HV-CF450T	8x5/16- 24	SGVM-HV-CF450M	8xM 8	114	80	92	304	142	164	71	226	159	12
DN 100 (4")	SGVM-HV-CF600T	16x5/16- 24	SGVM-HV-CF600M	16xM 8	152	80	130	369	170	192	85	277	166	12
DN 160 (6")	SGVM-HV-CF800T	20x5/16- 24	SGVM-HV-CF800T M	20xM 8	202	80	181	511	234	266	117	385	185	15
DN 200 (8")	SGVM-HV-CF1000T	24x5/16- 24	SGVM-HV-CF1000M	24xM 8	253	90	232	693	316	334	158	525	217	15
DN 250 (10")	SGVM-HV-CF1200T	32x5/16- 24	SGVM-HV-CF1200M	32xM 8	304	110	284	792	368	390	184	597	234	18

♦ Manual Lever SMART Gate Valves, HV, ISO-F Flange

Dimension in mm

Nominal I.D.	Part Number - Metric	Thread D	A	B	C	E	F	G	H	I	J	K
DN 63 (2.5")	SGVM-HV-ISOF63	4xM8	130	80	110	300	142	154	71	222	118	12
DN 100 (4")	SGVM-HV-ISOF100	8xM8	165	80	145	366	170	182	85	273	119	12
DN 160 (6")	SGVM-HV-ISOF160	8xM10	225	80	200	504	234	250	117	378	138	15
DN 200 (8")	SGVM-HV-ISOF200	12xM10	285	90	260	692	316	334	158	525	169	15
DN 250 (10")	SGVM-HV-ISOF250	12xM10	335	110	310	792	368	390	184	597	186	18

Product Order Information

Vacuum Valves

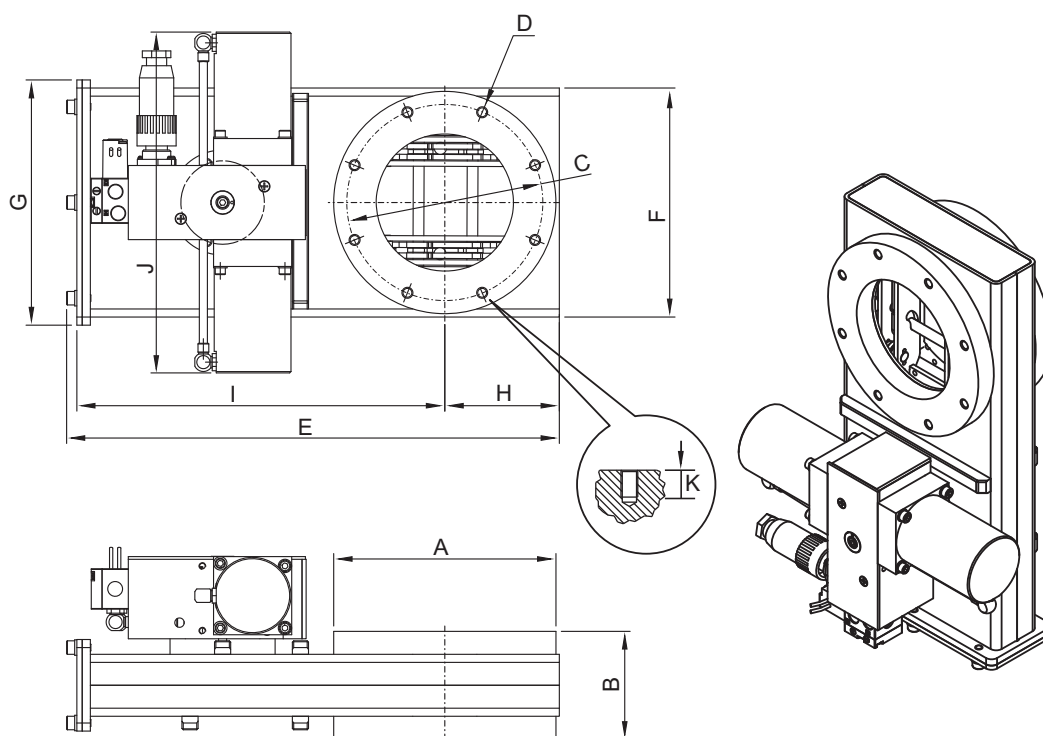

◆ Pneumatic SMART Gate Valves, HV, CF Flange

Dimension in mm

Nominal I.D.	Part Number- Inch	Thread D	Part Number- Metric	Thread D	A	B	C	E	F	G	H	I	J	K
DN 63 (2.5")	SGVP-HV-CF450T	8x5/16-24	SGVP-HV-CF450M	8xM8	114	80	92	300	142	154	71	222	230	12
DN 100 (4")	SGVP-HV-CF600T	16x5/16-24	SGVP-HV-CF600M	16xM8	152	80	130	366	170	182	85	273	253	12
DN 160 (6")	SGVP-HV-CF800T	20x5/16-24	SGVP-HV-CF800M	20xM8	202	80	181	504	234	250	117	378	299	15
DN 200 (8")	SGVP-HV-CF1000T	24x5/16-24	SGVP-HV-CF1000M	24xM8	253	90	232	693	316	334	158	525	388	15
DN 250 (10")	SGVP-HV-CF1200T	32x5/16-24	SGVP-HV-CF1200M	32xM8	304	110	284	792	368	390	184	597	386	18

◆ Pneumatic SMART Gate Valves, HV, ISO-F Flange

Dimension in mm

Nominal I.D.	Part Number- Metric	Thread D	A	B	C	E	F	G	H	I	J	K
DN 63 (2.5")	SGVP-HV-ISOF63	4xM8	130	80	110	300	142	154	71	222	230	12
DN 100 (4")	SGVP-HV-ISOF100	8xM8	165	80	145	366	170	182	85	273	253	12
DN 160 (6")	SGVP-HV-ISOF160	8xM10	225	80	200	504	234	250	117	378	299	15
DN 200 (8")	SGVP-HV-ISOF200	12xM10	285	90	260	692	316	334	158	525	388	15
DN 250 (10")	SGVP-HV-ISOF250	12xM10	335	110	310	792	368	390	184	597	386	18

Key Valve Parts

"In-Axis" is AdvanTorr's range of SMART gate valves that offers pneumatic only actuation with vertical orientation of the drive mechanism, making them ideal for when a small footprint is required within a system.

Features

- * In-Axis gate valve with integrated S.M.A.R.T. lock system.
- * Welded bellows feedthrough for longer life and ease of service.
- * Low particle generation for clean and sensitive environments.
- * Softshut gate mechanism, ideal for clean processes.

Vacuum Valves

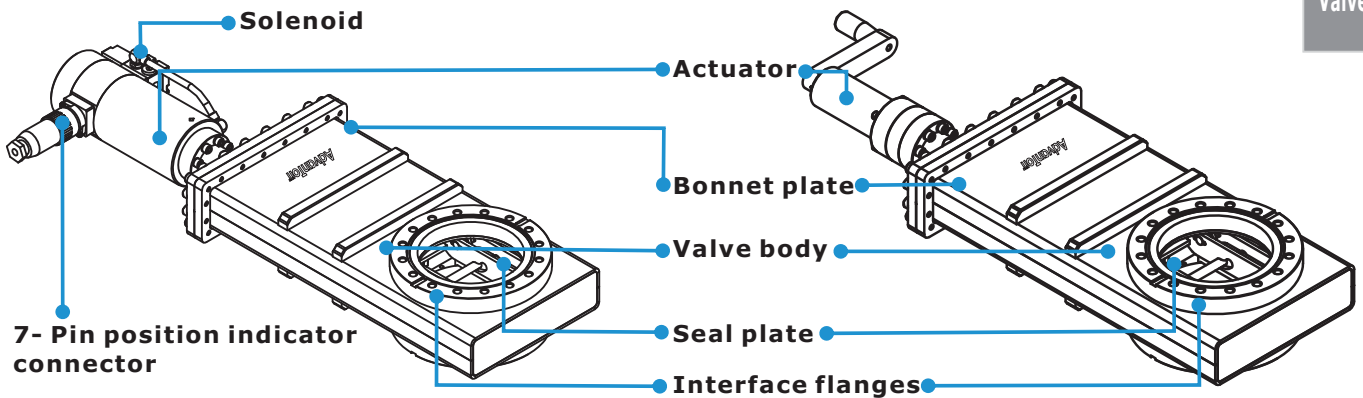

Technical Data for In- Axis Gate Valve

	Ultra High Vacuum	High Vacuum
Feedthrough	Welded bellows in AM350	Welded bellows in AM350
Gate seal	FKM o-ring (Optional for FFKM)	FKM o-ring (Optional for FFKM)
Bonnet seal	OFHC metal gasket	FKM O-ring
Operate pressure range	760 Torr ~ 1×10^{-10} Torr 1,000 mbar ~ 1.33×10^{-10} mbar 100 kPa ~ 1.13×10^{-11} kPa	760 Torr ~ 1×10^{-8} Torr 1,000 mbar ~ 1.33×10^{-8} mbar 100 kPa ~ 1.13×10^{-9} kPa
Leak rate	1×10^{-10} Torr l/s, He 1.33×10^{-10} mbar l/s, He 1.13×10^{-11} kPa l/s, He	1×10^{-9} Torr l/s, He 1.33×10^{-9} mbar l/s, He 1.13×10^{-10} kPa l/s, He
Cycle life	>50,000 Cycles	>200,000 Cycles
Temperature for valve body	250°C (482°F) Open, 200°C (392°F) Closed	
Temperature for actuator	100°C (212°F)	
Temperature for solenoid / position indicator	80°C 176°F	
Bake temperature	200°C (392°F) for FKM gate seal	100°C (212°F) for FKM gate seal
Valve body material	SS304L (Optional for SS316L)	
Mechanism material	SS304L	
Actuator material	SS304L, Aluminum	
Mounting position	Any	

Valve's operation data

Pneumatic operating pressure	4 bar ~ 8 bar 400 kpa ~ 800 kpa 58psi ~ 116 psi
Position indicator (included as standard)	Visual indicator and micro switch with 7-pin connector
Solenoid (included as standard)	24V DC, standard option for 12V DC, 110V AC and 220V AC
Failure protection (included as standard)	SMART lock system (valve position remains and locked)

Valve's performance data

	CF6"/ISO-F100	CF8"/ISO-F160	CF10"/ISO-F200	CF12"/ISO-F250
Maximum differential pressure against gate	<825 Torr <1,100 mbar < 109kpa			
Maximum differential pressure at opening	<22.5 Torr <30 mbar <3 kpa	<18.7 Torr <25 mbar <2.5 kpa	<15 Torr <20 mbar <2 kpa	<11.2 Torr <15 mbar <1.5 kpa
Pneumatic valve open / close time	1.5(s)	2(s)	2.5(s)	3(s)
Valve's conductance (Molecular flow)	1,700(l/s)	5,100(l/s)	12,000(l/s)	22,000(l/s)

Product Order Information

Vacuum Valves

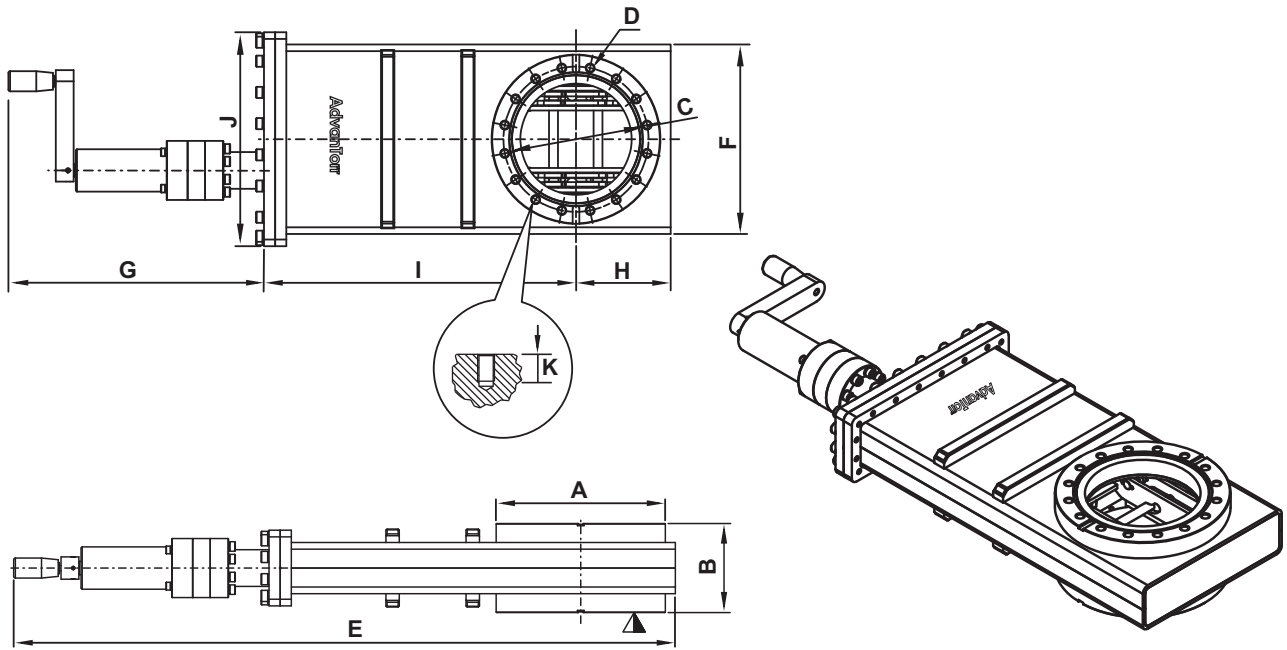

Manual In-Axis Gate Valves, UHV, CF Flange

Dimension in mm

Nominal I.D.	Part Number- Inch	Thread D	Part Number- Metric	Thread D	A	B	C	E	F	G	H	I	J	K
DN 63 (2.5")	AGVM-UHV-CF450T	8x5/16-24	AGVM-UHV-CF450M	8xM8	114	80	92	530	142	231	71	228	164	12
DN 100 (4")	AGVM-UHV-CF600T	16x5/16-24	AGVM-UHV-CF600M	16xM8	152	80	130	594	170	229	85	280	192	12
DN 160 (6")	AGVM-UHV-CF800T	20x5/16-24	AGVM-UHV-CF800M	20xM8	202	80	181	758	234	263	117	378	266	10
DN 200 (8")	AGVM-UHV-CF1000T	24x5/16-24	AGVM-UHV-CF1000M	24xM8	253	90	232	961	316	282	158	521	344	15
DN 250 (10")	AGVM-UHV-CF1200T	32x5/16-24	AGVM-UHV-CF1200M	32xM8	304	110	284	1142	368	356	184	603	402	18

Manual In-Axis Gate Valves, HV, CF Flange

Dimension in mm

Nominal I.D.	Part Number- Inch	Thread D	Part Number- Metric	Thread D	A	B	C	E	F	G	H	I	J	K
DN 63 (2.5")	AGVM-HV-CF450T	8x5/16-24	AGVM-HV-CF450M	8xM8	114	80	92	495	142	196	71	228	154	12
DN 100 (4")	AGVM-HV-CF600T	16x5/16-24	AGVM-HV-CF600M	16xM8	152	80	130	560	170	193	85	282	182	12
DN 160 (6")	AGVM-HV-CF800T	20x5/16-24	AGVM-HV-CF800M	20xM8	202	80	181	758	234	265	117	376	250	10
DN 200 (8")	AGVM-HV-CF1000T	24x5/16-24	AGVM-HV-CF1000M	24xM8	253	90	232	940	316	263	158	519	334	15
DN 250 (10")	AGVM-HV-CF1200T	32x5/16-24	AGVM-HV-CF1200M	32xM8	304	110	284	1142	368	355	184	603	402	18

Manual In-Axis Gate Valves, HV, ISO-F Flange

Dimension in mm

Nominal I.D.	Part Number- Metric	Thread D	A	B	C	E	F	G	H	I	J	K
DN 63 (2.5")	AGVM-HV-ISOF63	4xM8	130	80	110	495	142	196	71	228	154	12
DN 100 (4")	AGVM-HV-ISOF100	8xM8	165	80	145	560	170	193	85	282	182	12
DN 160 (6")	AGVM-HV-ISOF160	8xM10	225	80	200	758	234	265	117	376	250	10
DN 200 (8")	AGVM-HV-ISOF200	12xM10	285	90	260	940	316	263	158	519	334	15
DN 250 (10")	AGVM-HV-ISOF250	12xM10	335	110	310	1142	368	355	184	603	402	18

Product Order Information

Vacuum Valves

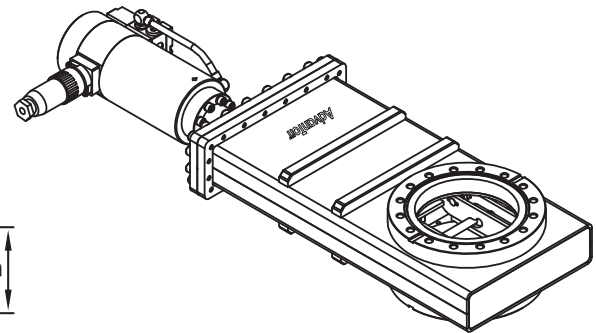
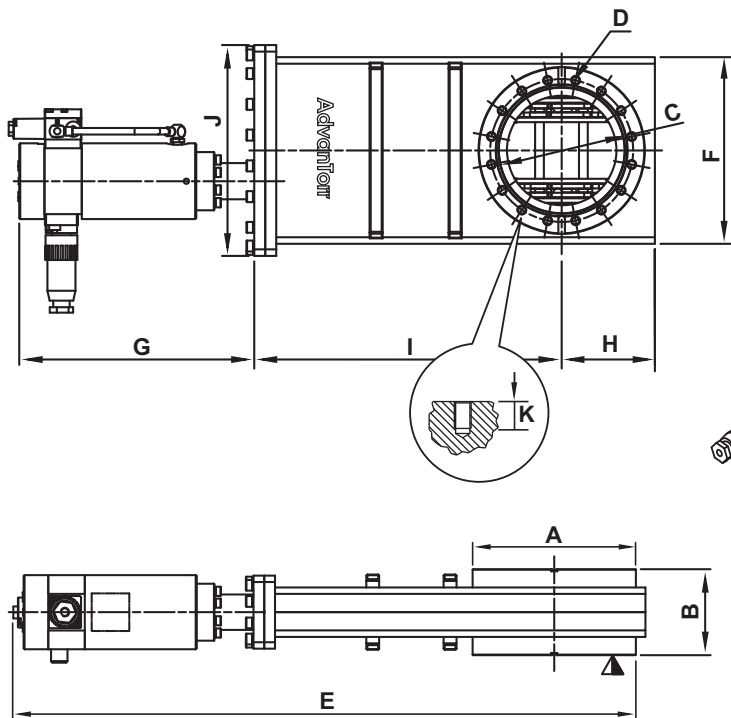

◆ Pneumatic In- Axis Gate Valves, UHV, CF Flange

Dimension in mm

Nominal I.D.	Part Number- Inch	Thread D	Part Number- Metric	Thread D	A	B	C	E	F	G	H	I	J	K
DN 63 (2.5")	AGVP-UHV-CF450T	8x5/16-24	AGVP-UHV-CF450M	8xM8	114	80	92	527	142	227	71	229	164	12
DN 100 (4")	AGVP-UHV-CF600T	16x5/16-24	AGVP-UHV-CF600M	16xM8	152	80	130	589	170	224	85	280	192	12
DN 160 (6")	AGVP-UHV-CF800T	20x5/16-24	AGVP-UHV-CF800M	20xM8	202	80	181	746	234	254	117	378	266	10
DN 200 (8")	AGVP-UHV-CF1000T	24x5/16-24	AGVP-UHV-CF1000M	24xM8	253	90	232	948	316	269	158	521	344	15
DN 250 (10")	AGVP-UHV-CF1200T	32x5/16-24	AGVP-UHV-CF1200M	32xM8	304	110	284	1131	368	345	184	602	402	18

◆ Pneumatic In- Axis Gate Valves, HV, CF Flange

Dimension in mm

Nominal I.D.	Part Number- Inch	Thread D	Part Number- Metric	Thread D	A	B	C	E	F	G	H	I	J	K
DN 63 (2.5")	AGVP-HV-CF450T	8x5/16-24	AGVP-HV-CF450M	8xM8	114	80	92	492	142	192	71	228	154	12
DN 100 (4")	AGVP-HV-CF600T	16x5/16-24	AGVP-HV-CF600M	16xM8	152	80	130	555	170	188	85	282	182	12
DN 160 (6")	AGVP-HV-CF800T	20x5/16-24	AGVP-HV-CF800M	20xM8	202	80	181	746	234	253	117	376	250	10
DN 200 (8")	AGVP-HV-CF1000T	24x5/16-24	AGVP-HV-CF1000M	24xM8	253	90	232	927	316	250	158	519	334	15
DN 250 (10")	AGVP-HV-CF1200T	32x5/16-24	AGVP-HV-CF1200M	32xM8	304	110	284	1131	368	345	184	603	402	18

◆ Pneumatic In- Axis Gate Valves, HV, ISO-F Flange

Dimension in mm

Nominal I.D.	Part Number- Metric	Thread D	A	B	C	E	F	G	H	I	J	K
DN 63 (2.5")	AGVP-HV-ISOF63	4xM8	130	80	110	491	142	192	71	228	154	12
DN 100 (4")	AGVP-HV-ISOF100	8xM8	165	80	145	555	170	188	85	282	182	12
DN 160 (6")	AGVP-HV-ISOF160	8xM10	225	80	200	746	234	253	117	376	250	10
DN 200 (8")	AGVP-HV-ISOF200	12xM10	285	90	260	927	316	250	158	519	334	15
DN 250 (10")	AGVP-HV-ISOF250	12xM10	335	110	310	1131	368	345	184	603	402	18

Aluminum Gate Valves

Vacuum Valves

Key Valve Parts

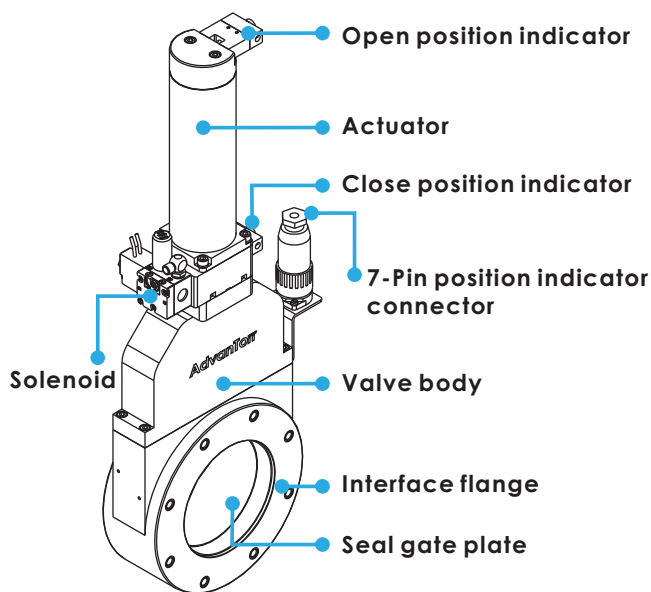

Valve's operation concept

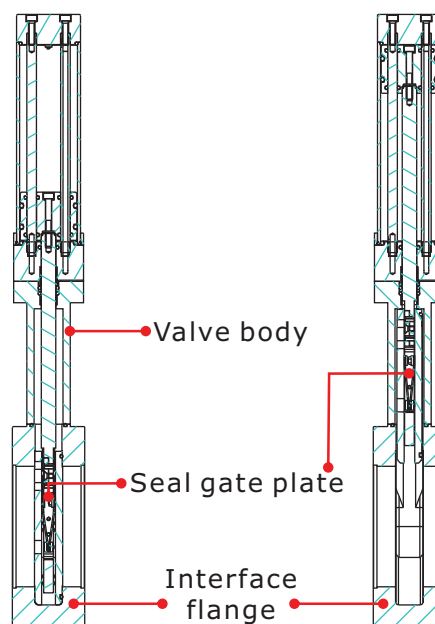

Closed position

Open position

Technical Data for Aluminum Gate Valve

	High Vacuum
Feedthrough	Rotary type feedthrough
Gate seal	FKM o-ring (Optional for FFKM)
Bonnet seal	FKM O-ring
Operate pressure range	DN100~DN200 1×10^{-7} mbar to 1.6 bar Dn250 1×10^{-7} mbar to 1.2 bar
Leak rate	1×10^{-9} mbar l/s ⁻¹
Cycle life	200,000 / 100,000 Cycles
Temperature for valve body	$\leq 120^{\circ}\text{C}$ (248 $^{\circ}\text{F}$)
Temperature for actuator	$\leq 80^{\circ}\text{C}$ (176 $^{\circ}\text{F}$)
Temperature for solenoid / position indicator	$\leq 50^{\circ}\text{C}$ (122 $^{\circ}\text{F}$)
Bake temperature	100 $^{\circ}\text{C}$ (212 $^{\circ}\text{F}$) for FKM gate seal
Valve body material	Aluminum
Mechanism material	SS304L, SS303L, SS420L, Aluminum
Actuator material	Aluminum
Mounting position	Any

Valve's operation data

Pneumatic operating pressure	4 bar~7 bar
Position indicator (included as standard)	Visual indicator and micro switch with 7-pin connector
Solenoid (included as standard)	24V DC, standard option for 12V DC, 110V AC and 220V AC
Failure protection (included as standard)	Roller Lock (valve position remains and locked)

Valve's performance data

	ISO-F100	ISO-F160	ISO-F200	ISO-F250
Maximum differential pressure against gate	<1,200 Torr <1,600mbr <160kPa	<900 Torr <1,200mbr <120kPa	<900 Torr <1,200mbr <120kPa	<900 Torr <1,200mbr <120kPa
Maximum differential pressure at opening	<1,200 Torr <1,600mbr <160kPa	<900 Torr <1,200mbr <120kPa	<900 Torr <1,200mbr <120kPa	<900 Torr <1,200mbr <120kPa
Pneumatic valve open / close time	2(s)	2(s)	3(s)	5(s)
Valve's conductance (Molecular flow)	2,000 (l/s)	6,000 (l/s)	12,000 (l/s)	22,000 (l/s)

Product Order Information

◆ Figure 1

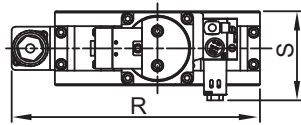

◆ Figure 2

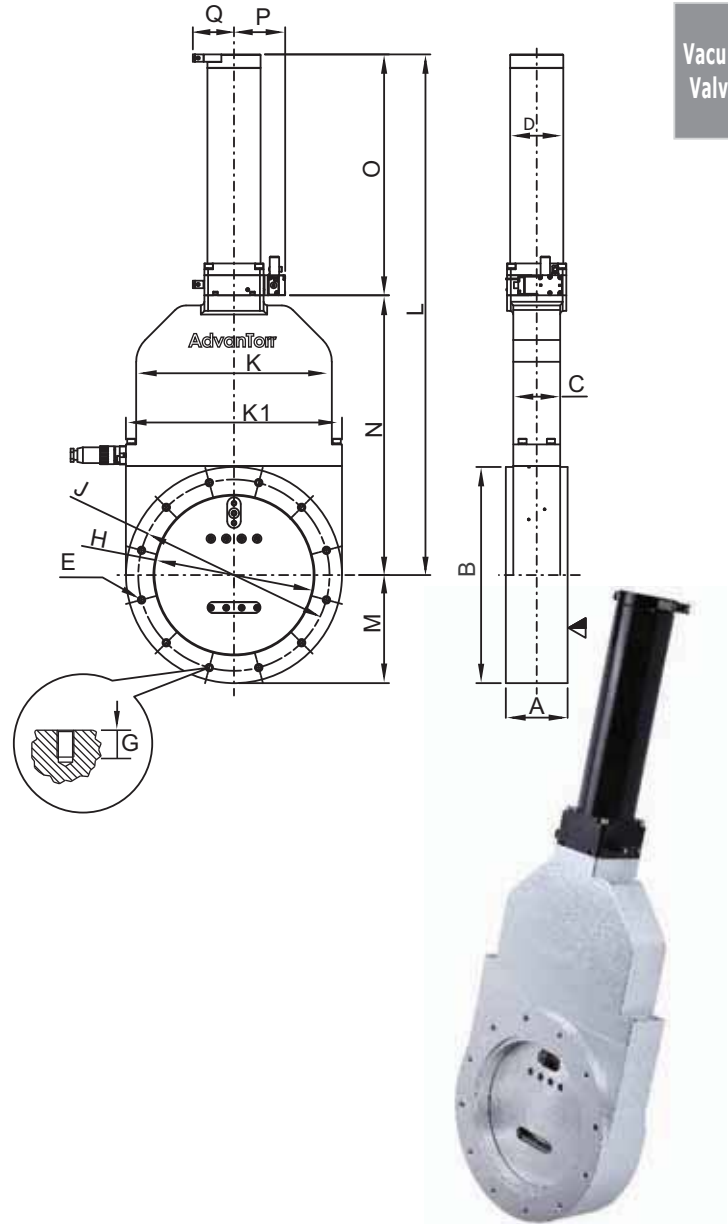
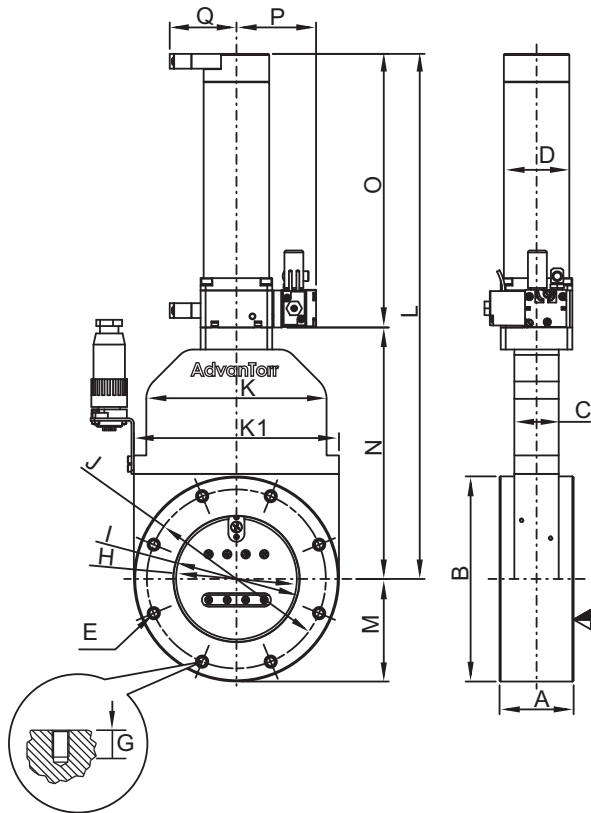
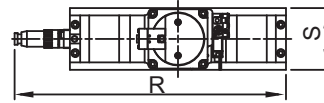

Vacuum Valves

◆ Pneumatic Aluminum Gate Valves

Dimension in mm

Part Number	Tube OD	Figure	A	B	C	D	Thread E	G	H	I	J
AGV-HV-ISOF100	4"	1	60	166	36	53	8xM8	12	100	102	145
AGV-HV-ISOF160	6"	1	70	237	58	65	8xM10	16	150	153	200
AGV-HV-ISOF200	8"	1	80	288	66	75	12xM10	16	200	213	260
AGV-HV-ISOF250	10"	2	100	350	76	86	12xM10	16	261	-	310

K	K1	L	M	N	O	P	Q	R	S
146	166	425	83	204	222	65	54	201	72
192	237	547	119	280	267	70	60	319	78
243	288	688	144	364	325	72	62	323	83
317	350	843	175	453	390	83	67	440	100

Key Valve Parts

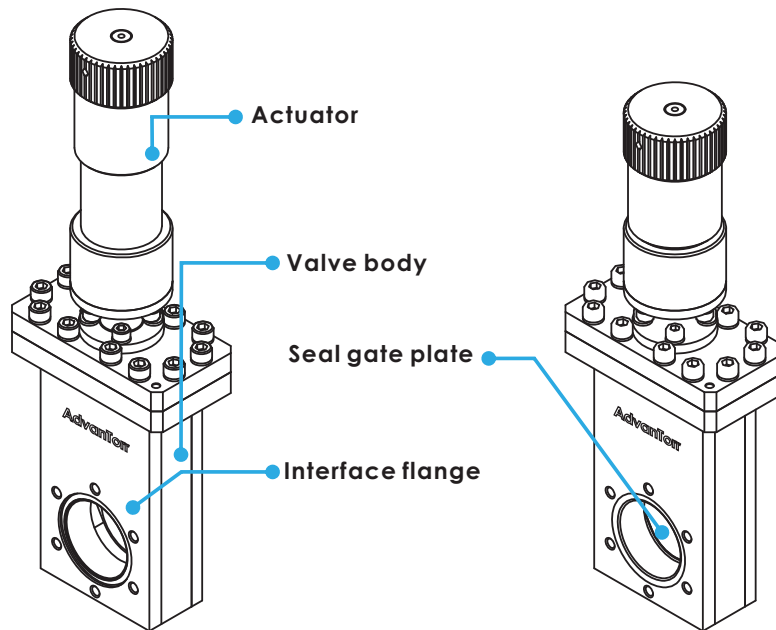

Vacuum
Valves

Technical Data for Kompact Gate Valve

	Ultra High Vacuum
Feedthrough	Weld-bellows in AM350
Gate seal	FKM o-ring with bonding on the metal
Bonnet seal	Metal gasket
Operate pressure range	1×10^{-10} mbar to 2 bar(abs)
Leak rate (bosity/ valve seat)	$< 5 \times 10^{-10}$ / $< 1 \times 10^{-9}$ mbar l/s
Cycle life	>50,000 Cycles
Temperature for valve body	$\leq 250^\circ\text{C}$ (482°F) open, $\leq 200^\circ\text{C}$ (392°F) closed
Temperature for actuator	$\leq 200^\circ\text{C}$ (392°F)
Temperature for solenoid / position indicator	$\leq 50^\circ\text{C}$ (122°F) / $\leq 80^\circ\text{C}$ (176°F)
Bake temperature	200°C (392°F) for FKM gate seal
Valve body material	Optional for SS304L and SS316L
Mechanism material	Stainless steel, Aluminum
Actuator material	Aluminum
Mounting position	Any

Valve's operation data

Pneumatic operating pressure	1×10^{-10} mbar to 2 bar(abs)
Compressed air pressure min.- max. Overpressure.	5~7 bar
Position indicator (included as standard)	Stainless steel, $\leq 200^\circ\text{C}$ (392°F)
Solenoid (included as standard)	24V DC, standard option for 12V DC, 110V AC and 220V AC
Failure protection (included as standard)	Build in SMART lock system (Valve position remain and locked)

Valve's performance data

	CF2.75
Maximum differential pressure against gate	≤ 2 bar in either direction
Maximum differential pressure at opening	≤ 30 mbar
Pneumatic valve open / close time	0.7 (s)
Valve's conductance (Molecular flow)	220 (l/s)

Key Valve Parts of Gate Valve- Single Acting _____

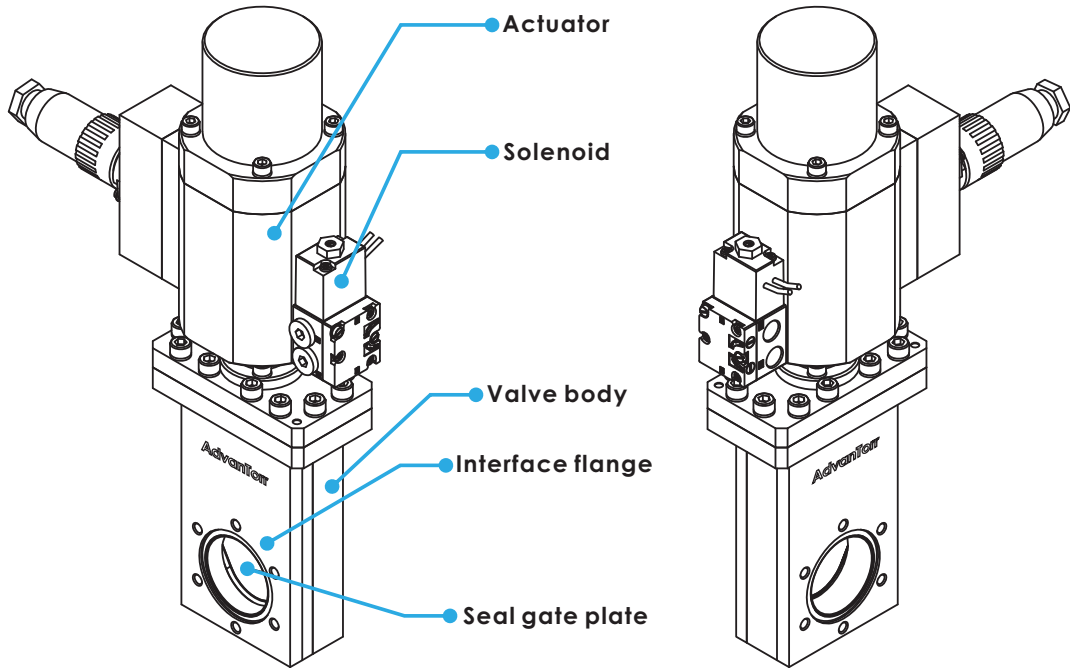

Key Valve Parts of Gate Valve- Double Acting _____

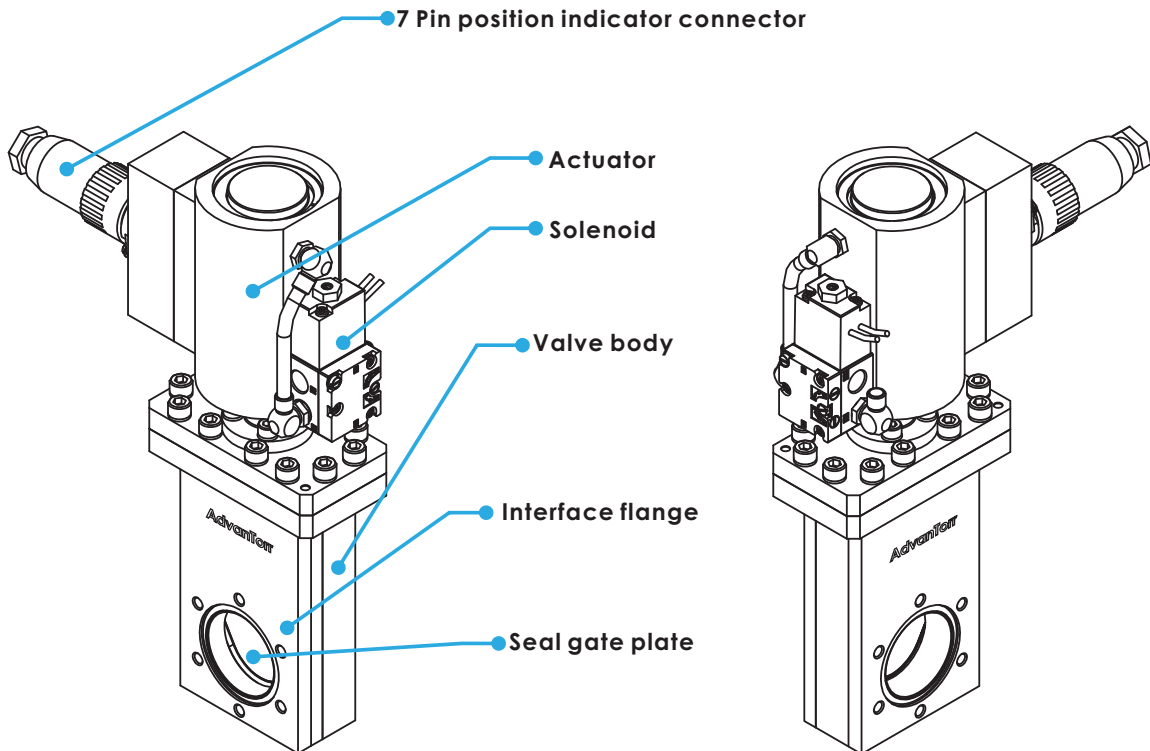

Product Order Information

Vacuum Valves

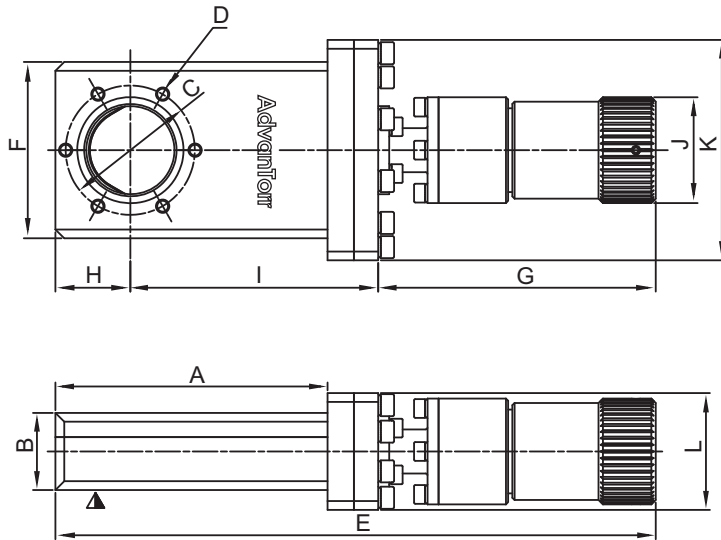

◆ UHV Manual Kompact Gate Valves

Dimension in mm

Part Number	Tube OD	A	B	C	D	E	F	G	H	I	J	K	L
KGM-UHV-CF-275	40	124	35	59	6xM6	273	80	126	34	113	48	100	53

Product Order Information

Figure 1- Single Acting

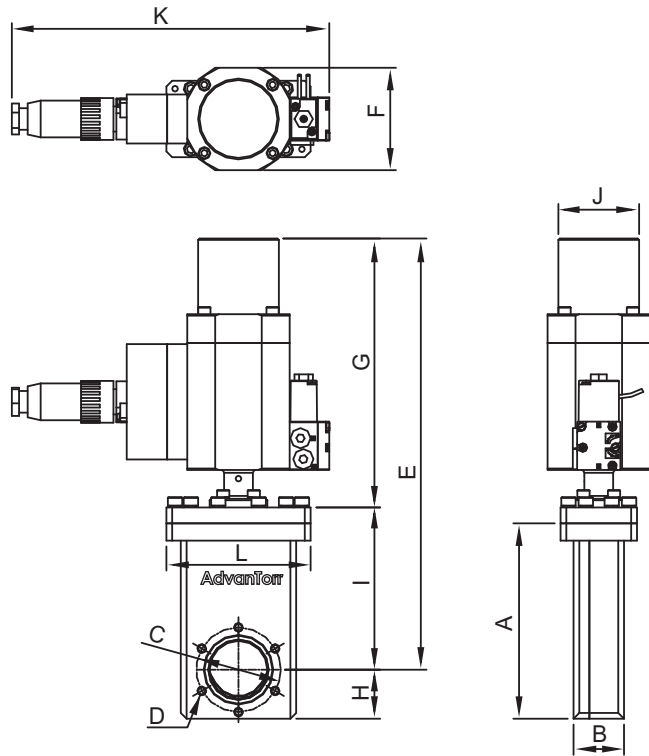

Vacuum Valves

Figure 2- Double Acting

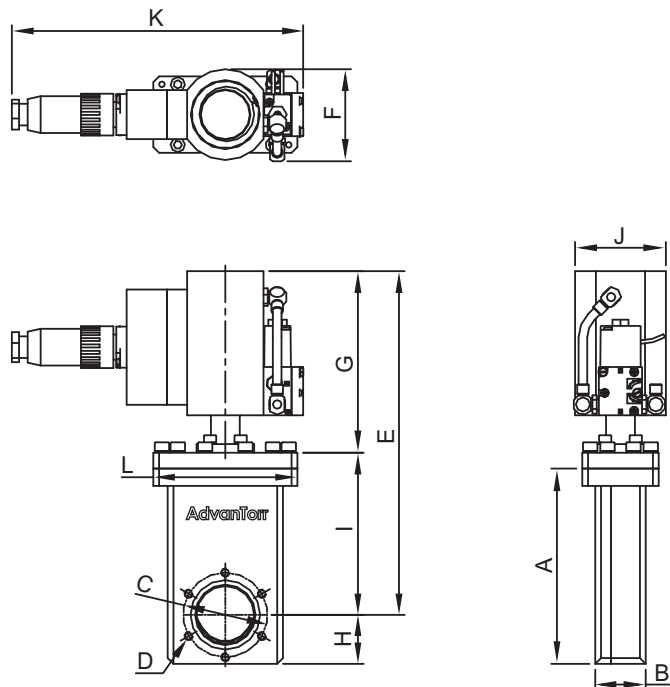

◆ UHV Pneumatic Kompact Gate Valves

Dimension in mm

Part Number	Tube OD	Figure	A	B	C	D	E	F	G	H	I	J	K	L
KGP-UHV-CF-275-S	40	1	136	35	59	6xM6	299	71	187	34	113	56	220	100
KGP-UHV-CF-275-D	40	2	136	35	59	6xM6	239	64	126	34	113	63	202	100